

1 Included with these Instructions:

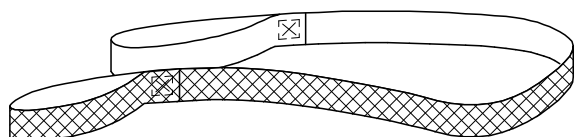

Strap x 1

Fit the Strap to the back long rail.

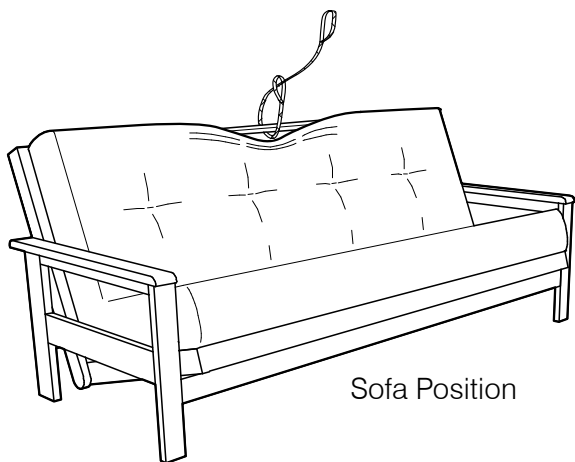

Sofa Position

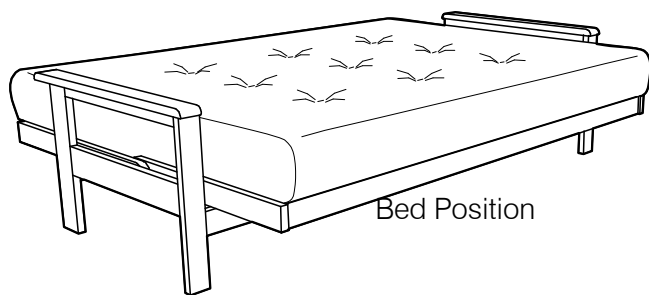

Bed Position

2 Sofa to Bed Position

A

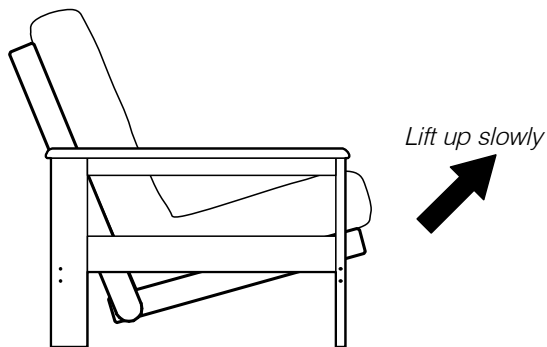

Pull up gently, and let the back drop down slowly.

B

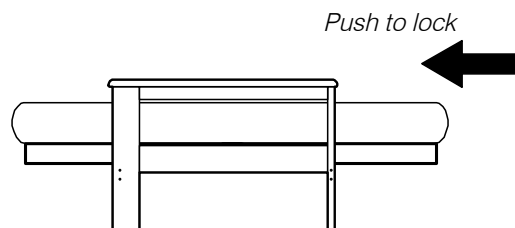

Lock in bed position.

C

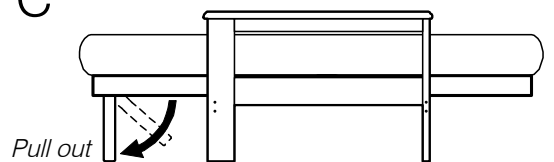

Queen size only:- Pull out the short legs.

3 Bed to Lounge and Sofa Position

A

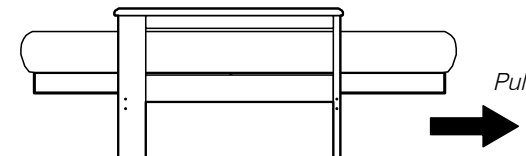

Pull out to unlock - Don't forget!

B

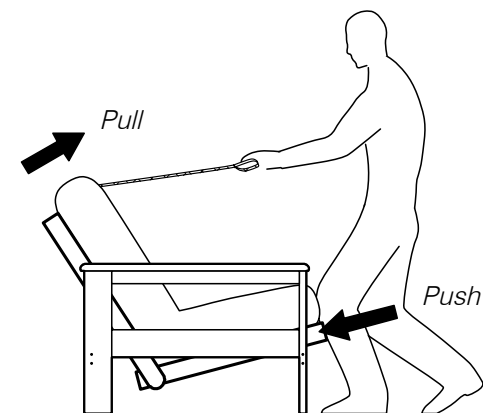

Use the Strap to pull the Back deck forward. As it rises, you can use your knee to push the Seat until it locks into a lounge position.

C

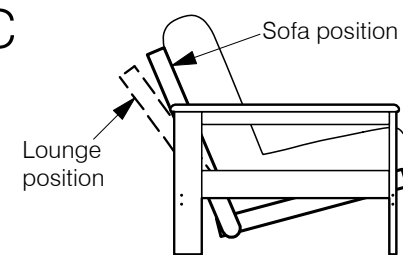

Pull further and it will lock into a sofa position.