

Assembly Instructions

BIFOLD FUTON FRAME FUTON ARMS

See below for Preparation of arms for assembly.

Key West-0104

1 One pair of Bifold Arms.

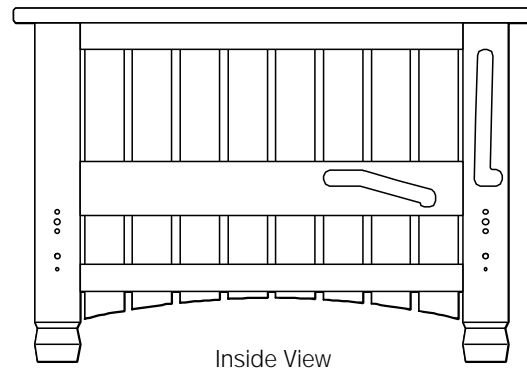
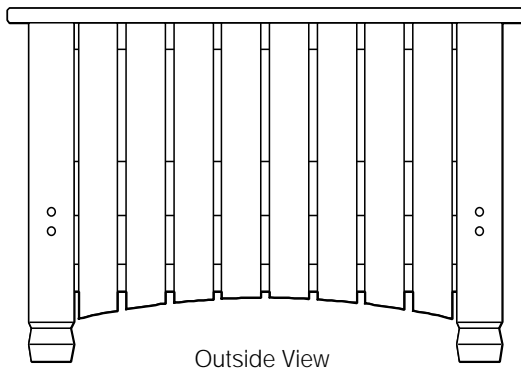

2 Hardware in this box.

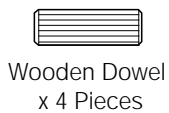
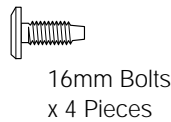
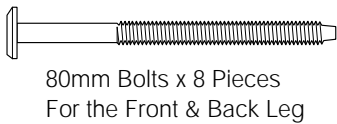

3 Fasten Stretcher Brackets to Arm.

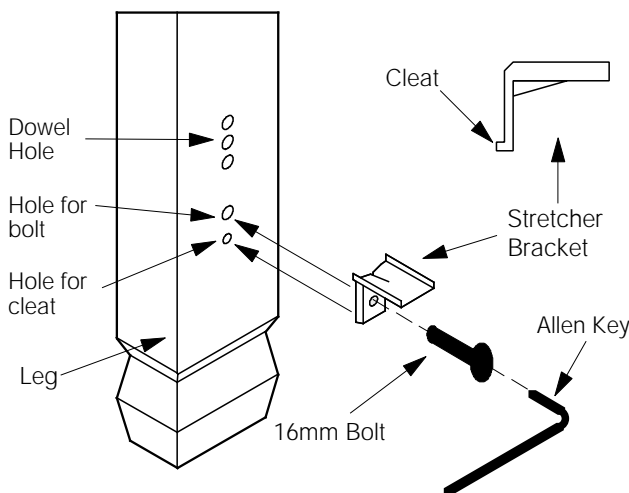

- Insert the Stretcher Bracket Cleat into the hole provided.
- IMPORTANT:** Don't fully tighten Bracket until Stretchers are all in place for easy alignment.
- Each arm requires two brackets, front and back.

4 Assemble the Bifold Body.

BODY INSTRUCTIONS: Instructions for assembly of arms to the Bifold Body are in the BODY box.

NOTE: Fitting Wooden Dowels

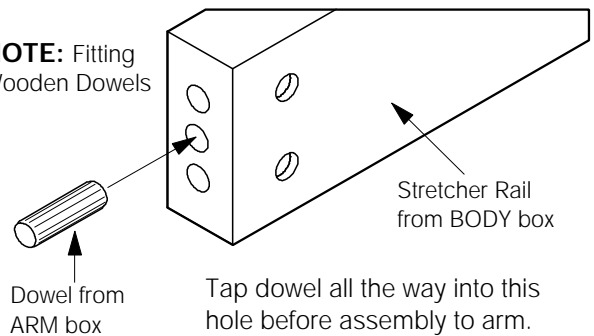

! SPECIAL NOTE: Back and Seat Assembly.

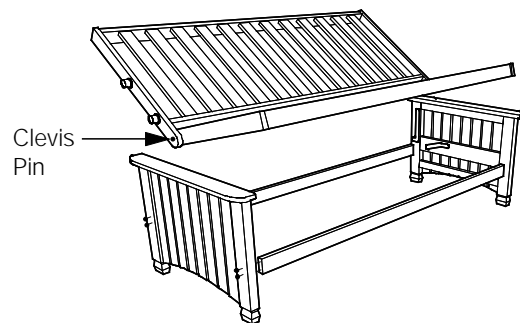

Contrary to Assembly Instructions in the BODY box, You will need to join both the Back Deck and the Seat Deck together, as shown, before fitting them between the Arms.

5 Fir Wood Buttons into Arm Holes.

AFTER TOTAL ASSEMBLY:

Push fit or lightly tap the wooden buttons into the bolt holes on the arms.

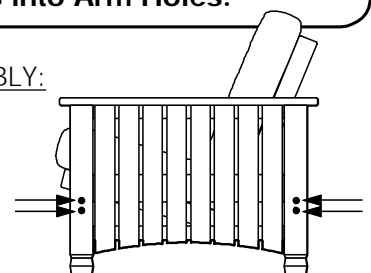

i Instructions for Bifold Body assembly, are packed in the Body box.