

## A Seating position to Bed position.

With both hands, lift the Seat from the front until it is in the "lock" position.

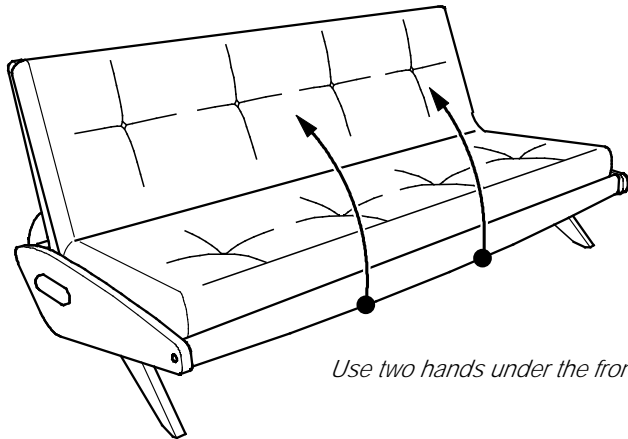

## The "lock" position.

With one foot on the Foot Plate, push the Seat forward 1" to disengage the "lock", and lift the Seat upwards.

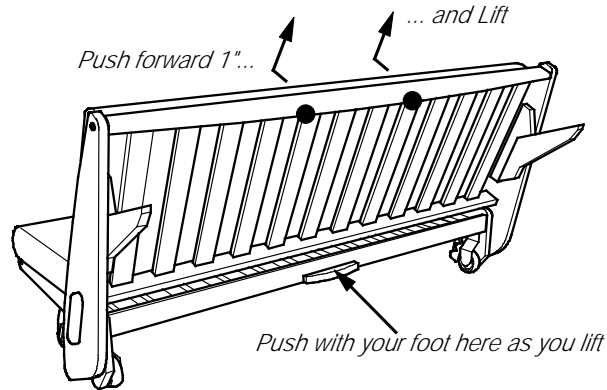

## The Bed position.

Gently lower the Seat down to the Bed position.

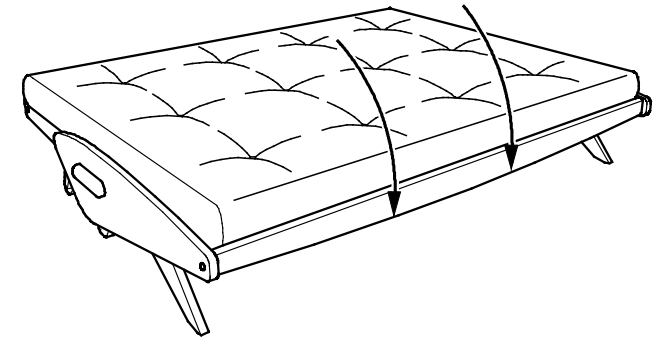

## B Bed position to Seating position.

With both hands, lift the Seat from the front until it is in the "lock" position.

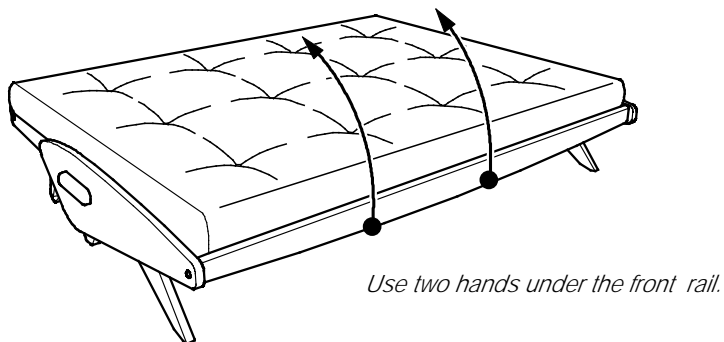

## The "lock" position.

With the Back and Seat locked together, lower down the frame to the Seating position.

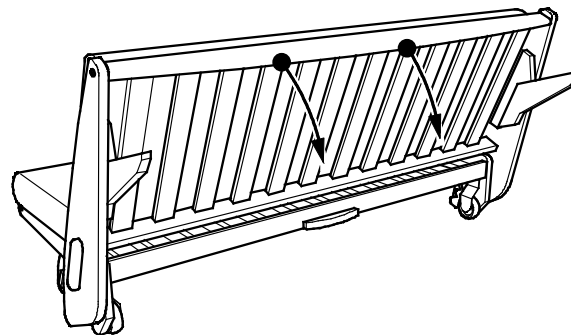

## C Adjusting the Seating position.

Pull on the Strap to adjust the Seating upright.

