

Assembly Instructions

BIFOLD FUTON FRAME

TRINITY

Instructions apply to all sizes:

Chair • Full/Double
Love seat • Queen

1PA-0701

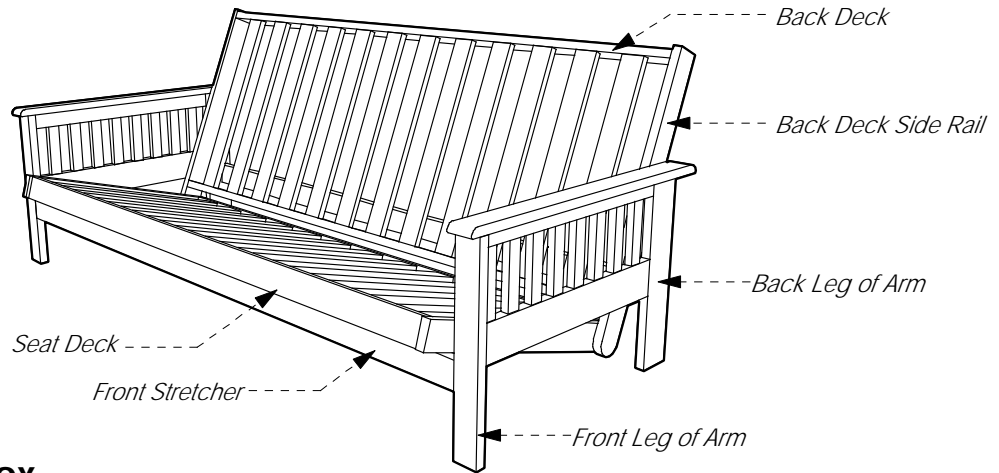

1A Parts in this box.

Chair size please note:

The Back Deck and Side Rails are already assembled. Please skip instructions on Page 3.

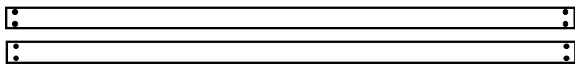

Stretchers **x 2**
(Full size illustrated)

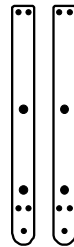

Side rails **x 2**

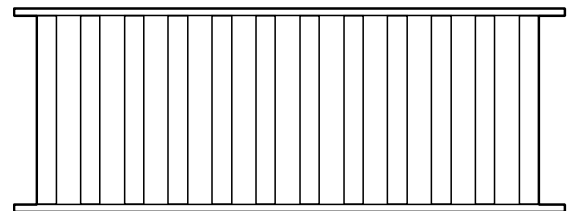

Back Deck **x 1**
(Full size illustrated)

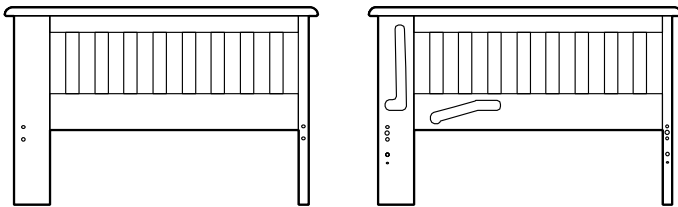

Arms **x 2**

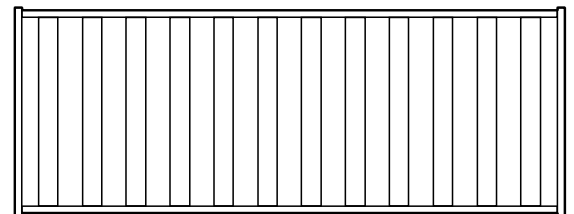

Seat Deck **x 1**
(Full size illustrated)

1B Hardware in this box.



Barrel nuts
x 16

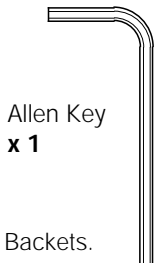

Allen Key
x 1



16mm Bolts **x 4**
For the Stretcher Brackets.



60mm Bolts **x 12**
For the Side Rails and Back Leg.



100mm Bolts **x 4**
For the Front Leg.

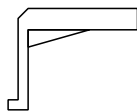

Stretcher Brackets
x 4

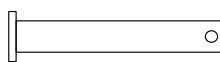

Clevis Pins
x 2



Wood Button
x 4



Locking Pins
x 2



Washers
x 2

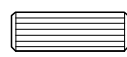

Wooden Dowel
x 4

1C Full size only: Extra Parts.

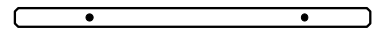

Slat Supports **x 2**



30mm Bolts **x 4**

1D Queen size only: Extra parts.

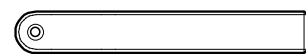

Small Leg **x 2**



50mm Bolts **x 2**

2A Fasten Stretcher Brackets to Arm.

- Insert the Stretcher Bracket Cleat into the hole provided.
- IMPORTANT:** Don't fully tighten Bracket until Stretchers are all in place for easy alignment.
- Each arm requires two brackets, front and back.

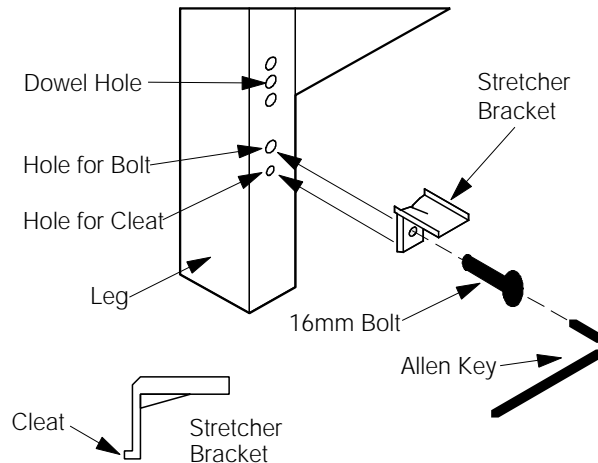

2B Fit Wooden Dowels

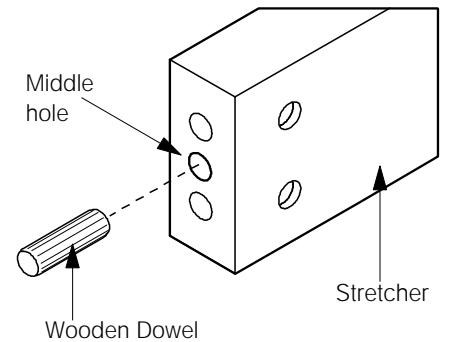

Tap dowels all the way into the middle hole at each end of the Stretchers.

2C Attach Arms to Stretchers.

Using Bolts and Barrel Nuts provided with the Arms, attach the Arms **LOOSELY** to the Stretchers as shown..
It is important that these bolts are left **LOOSE!**

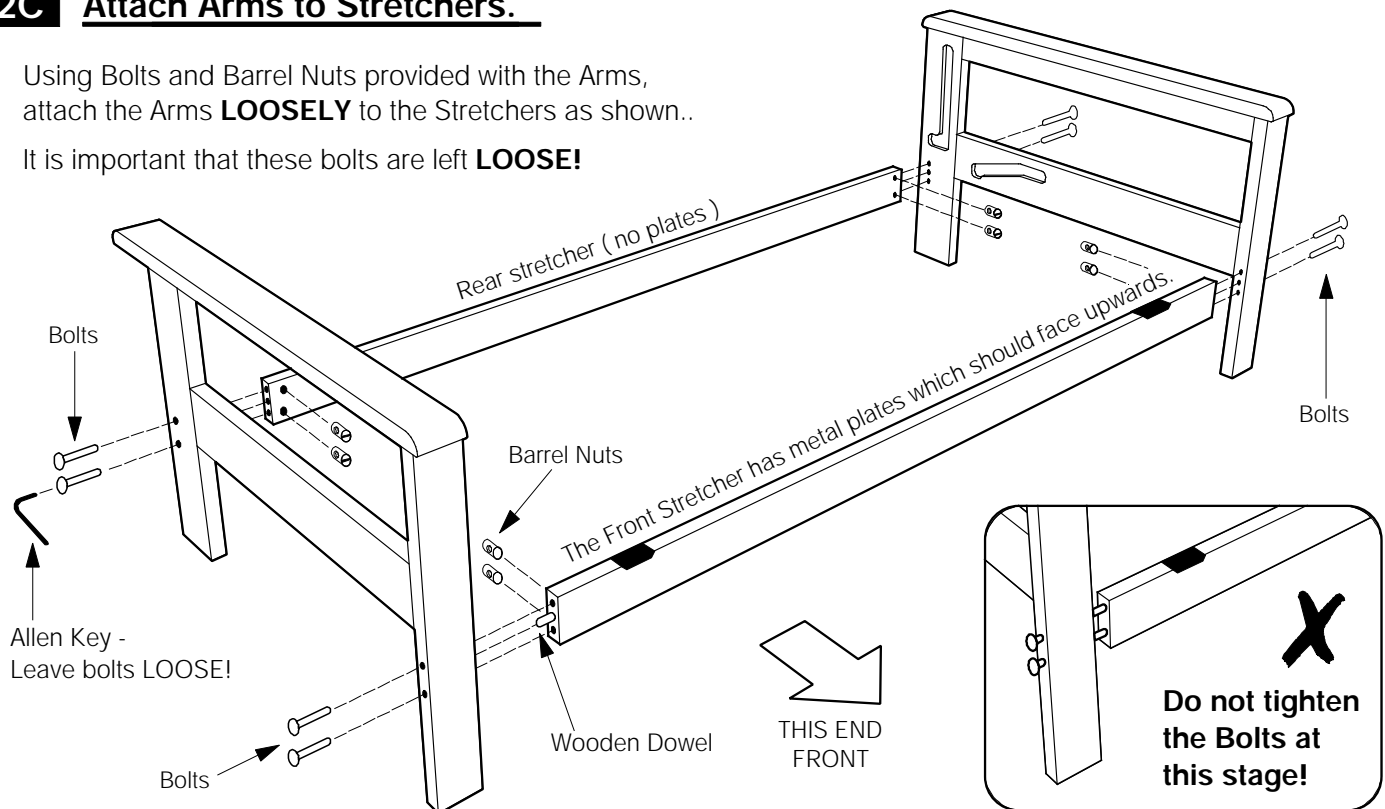

BOLT AND BARREL NUT ASSEMBLY SYSTEM

- ✓ Insert Barrel Nuts as shown using a screwdriver. This will help you position the Nut in line with the Bolt.
- ✓ Do not force the Bolt as you may strip the thread. Be sure the thread is properly started.

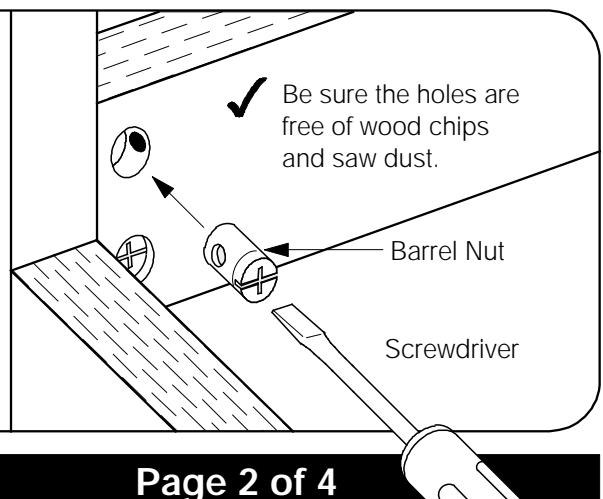
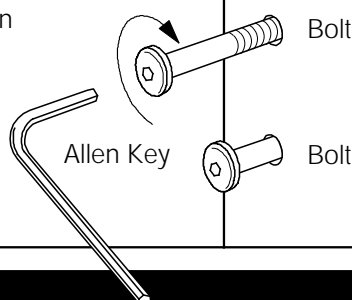

3A Attach the Side Rails to the Back Deck.

Using the Bolts and Barrel Nuts packed in this box, attach the Back Side Rails to the Back Deck.

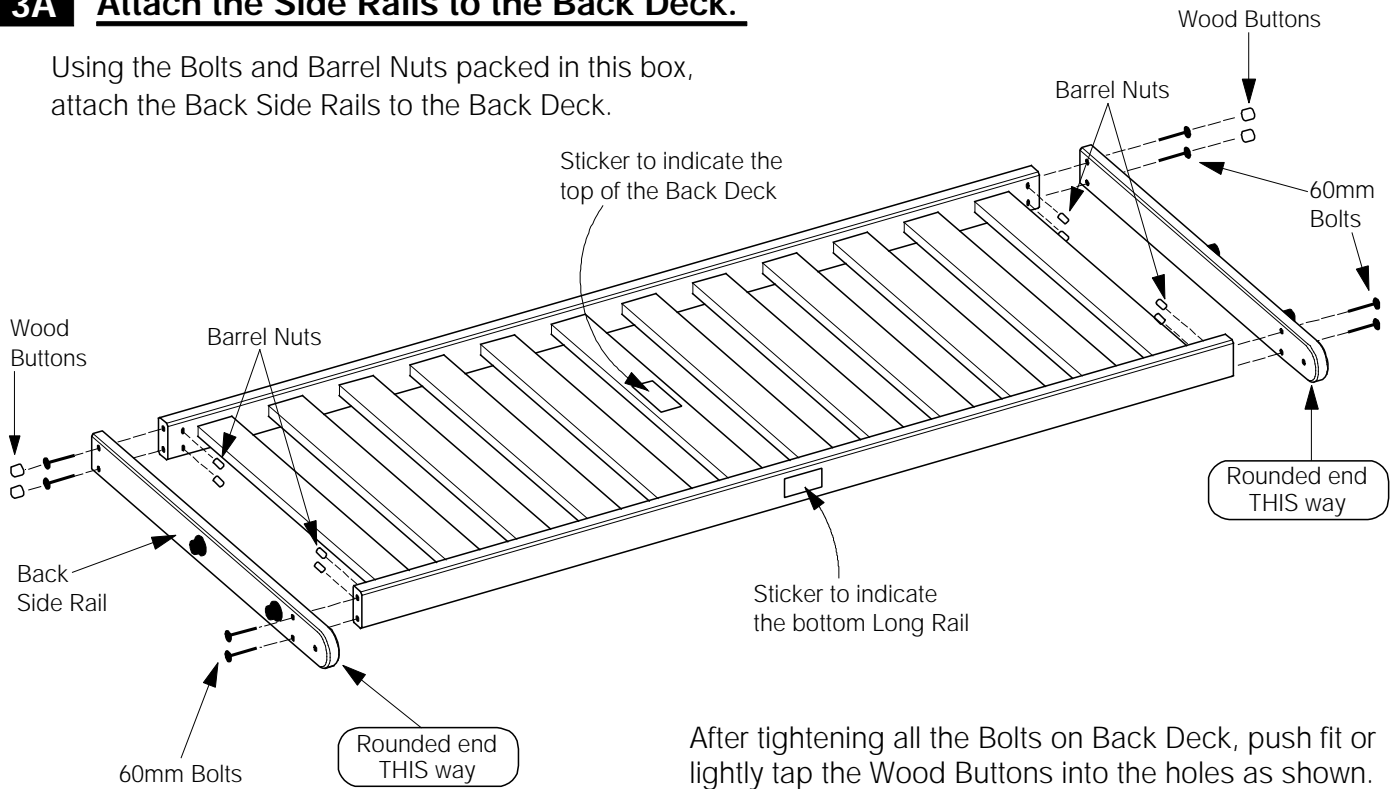

After tightening all the Bolts on Back Deck, push fit or lightly tap the Wood Buttons into the holes as shown.

3B Full size only: Bolt the Slat supports to Seat and Back Deck.

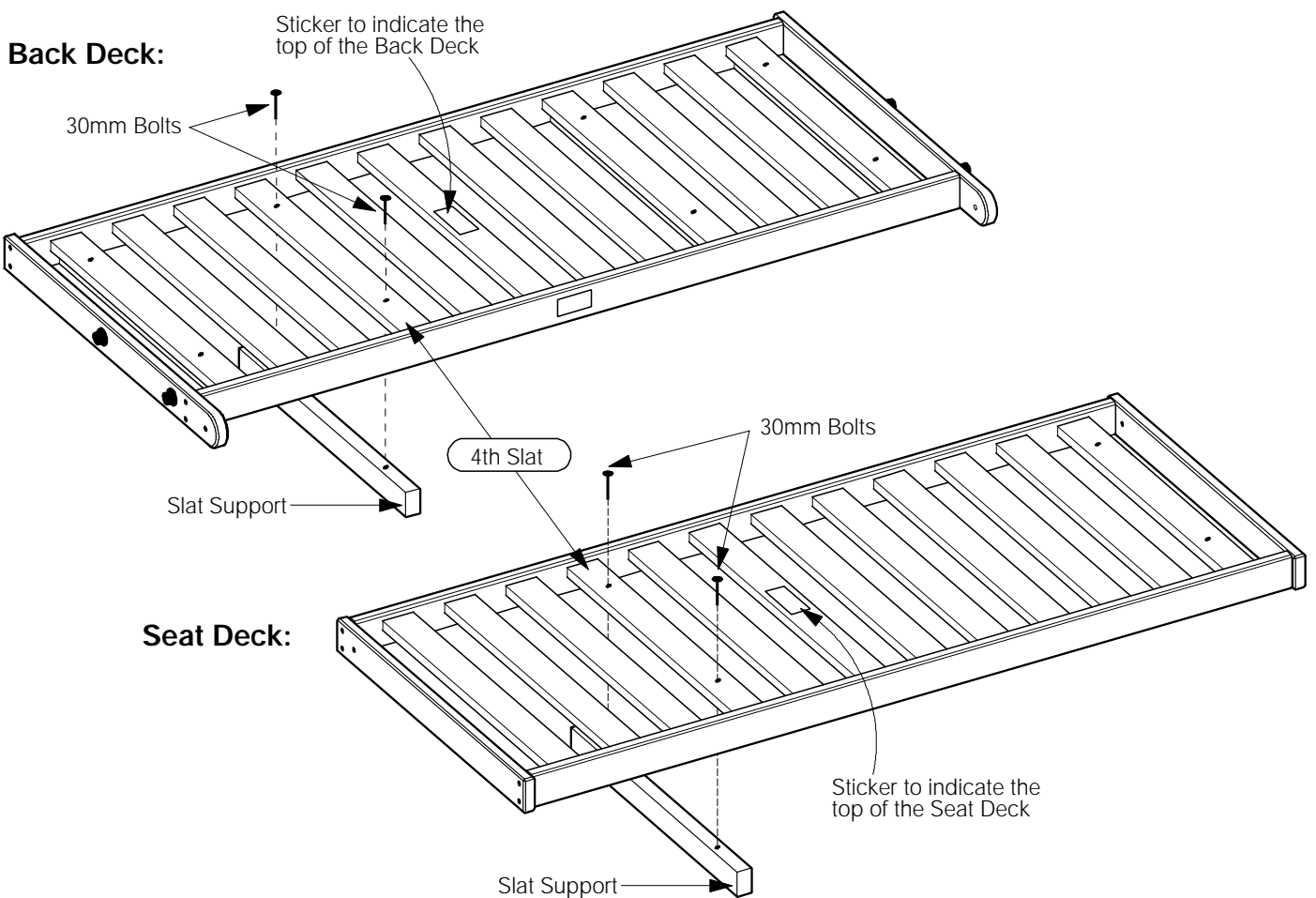

4A Fit Back Deck into Position.

A. Insert the Back Deck lying flat. Insert one end first, then gently lower the other end into position.

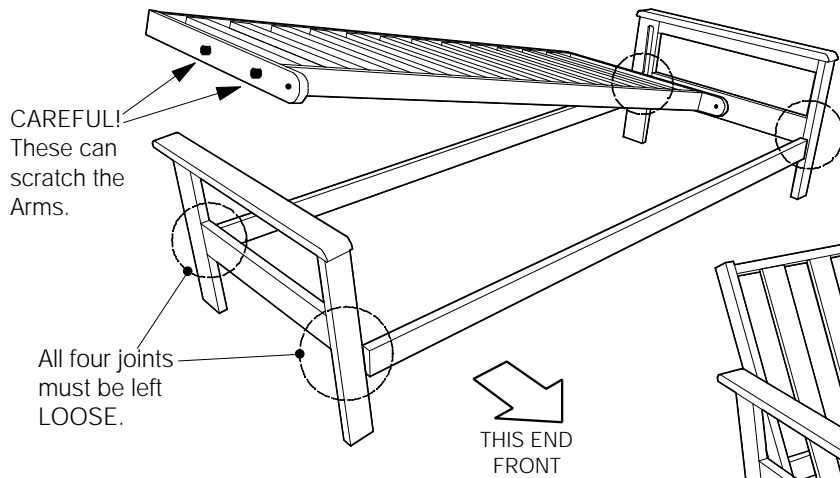

Your arm style may vary

- ✓ This step can be tricky - it is best done with two people
- ✓ Remember that the Bolts on the Arm should be LOOSE.
- ✗ Be careful not to scratch the Arms with the Plastic Runners when you lower the ends of the Back Deck.

B. When you have the Back Deck fitted lying flat, tighten all the Bolts. From the back, lift the Back Deck to upright as illustrated.

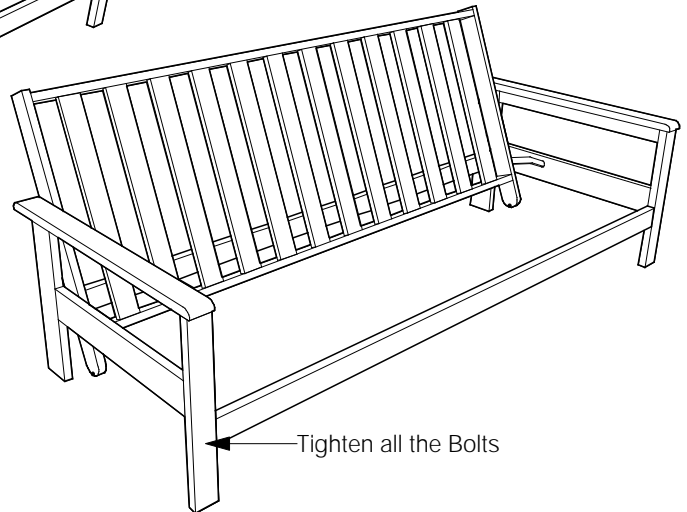

4B Fit Seat Deck into Position.

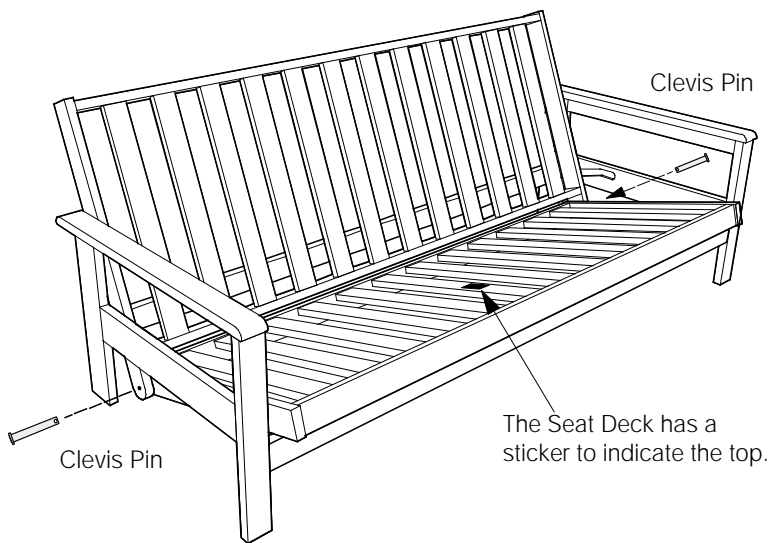

Fit the seat deck between the Arms and into the Back Deck as shown. Use the Clevis Pins to connect the two decks. Secure with a Washer and Locking Pin.

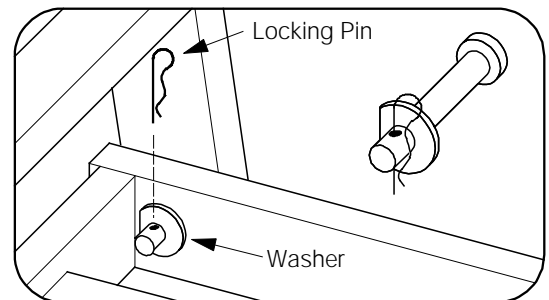

4C Queen size only: Attach short legs.

