

**1A** One Pair of Shoe Fittings Arms:

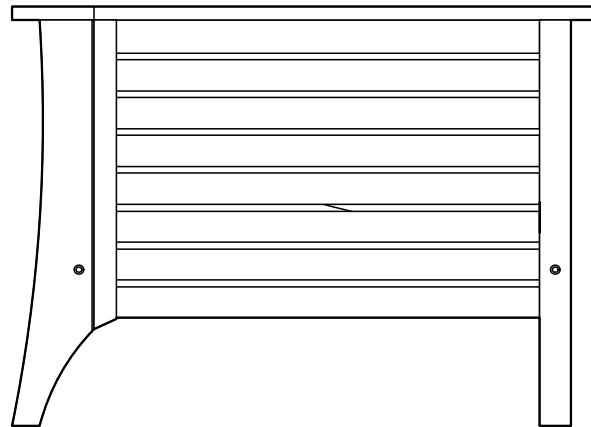

Outside View

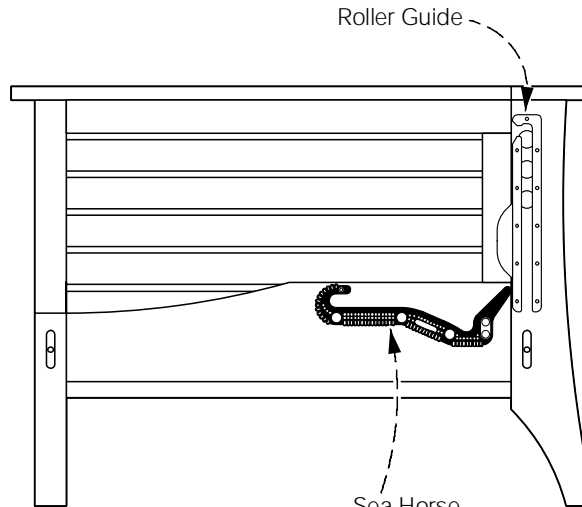

Inside View

Roller Guide

Sea Horse



featuring the Rubber

SEA HORSE™

**1B** Hardware in this Box:



ThumNut™ x 4 pieces  
Patent No.: US 6,457,923

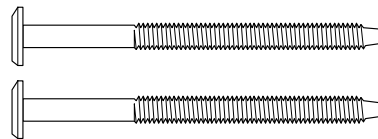

80mm Bolts x 2 pieces  
(for Back Leg)

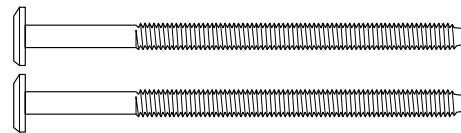

100mm Bolts x 2 pieces  
(for Front Leg)

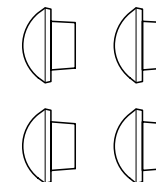

Wood Buttons  
x 4 pieces



Allen Key  
x 1 piece

## 2A Attach Stretchers to Arms

Using Bolts and ThumNuts™ provided with the Arms, attach the Arms to the Stretchers as shown.

The raised side of the stretcher should face upwards.

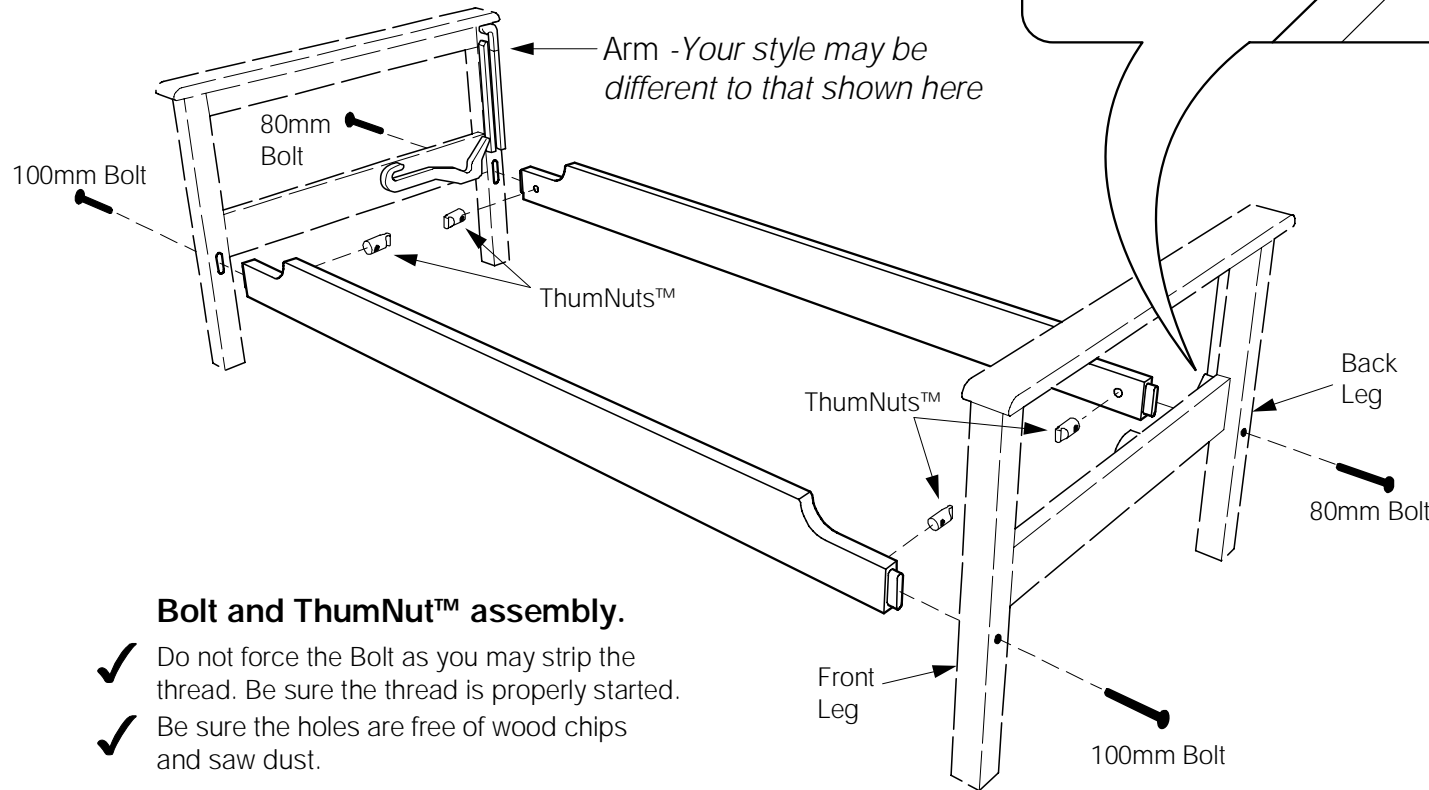
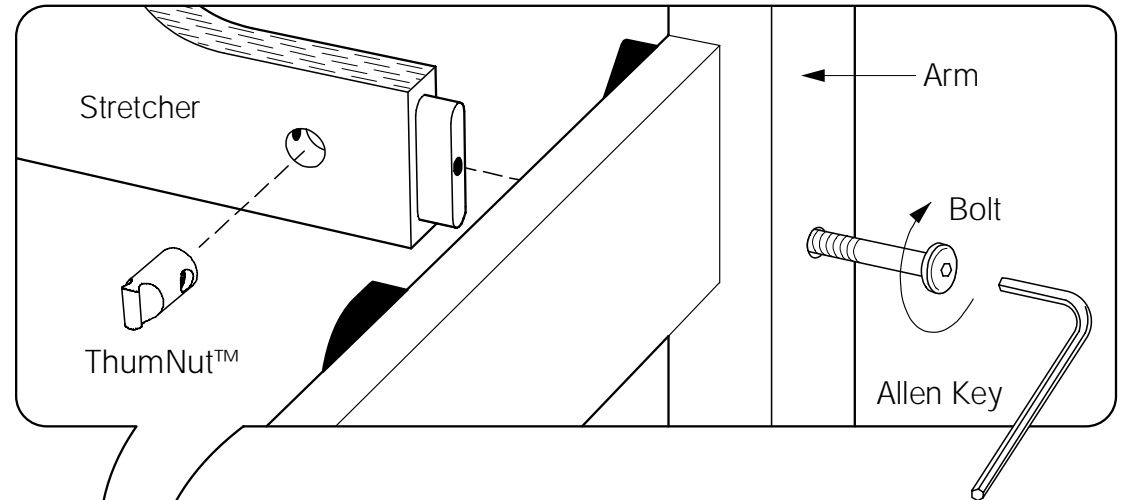
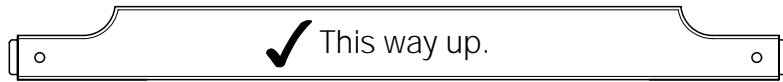

### Bolt and ThumNut™ assembly.

- ✓ Do not force the Bolt as you may strip the thread. Be sure the thread is properly started.
- ✓ Be sure the holes are free of wood chips and saw dust.

## 2B Fit Wood Buttons into Bolt Holes.

Tighten all Bolts. Push fit or lightly tap the Wood Buttons into the Bolt holes on the Arms.

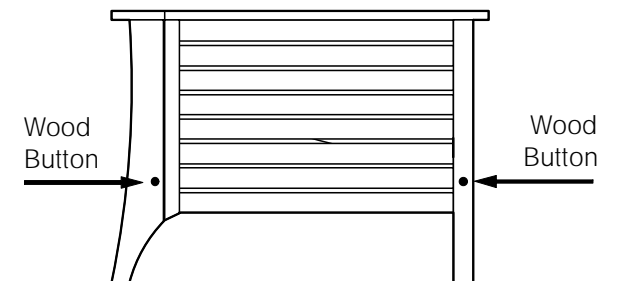

**3A** Carefully lift the Back Deck into position. Place the Bottom Rollers onto the back of the Rubber Sea Horse.

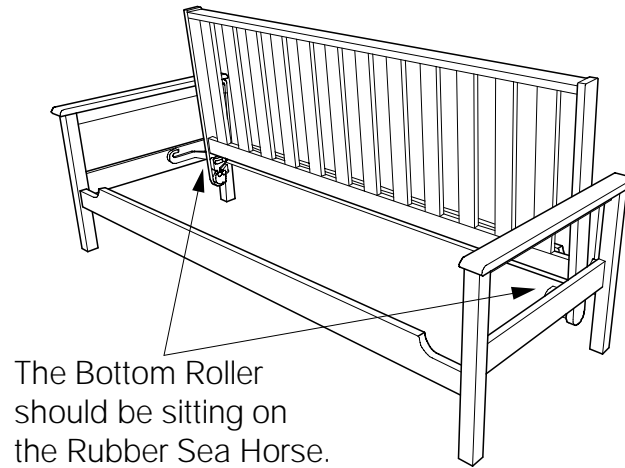
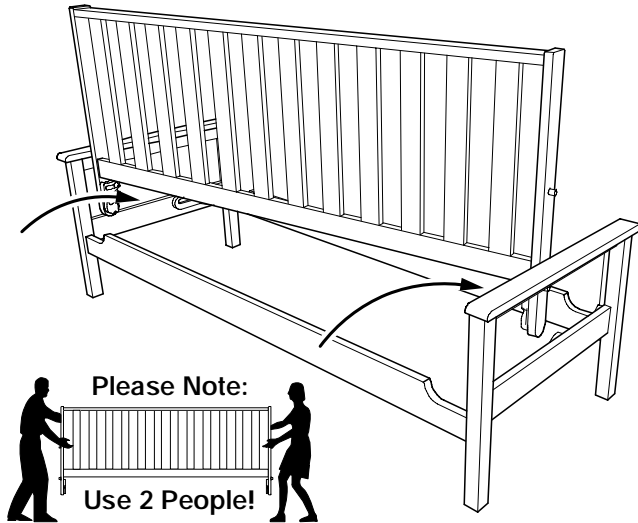

**3B** Rest the Top Rollers against the Leg.

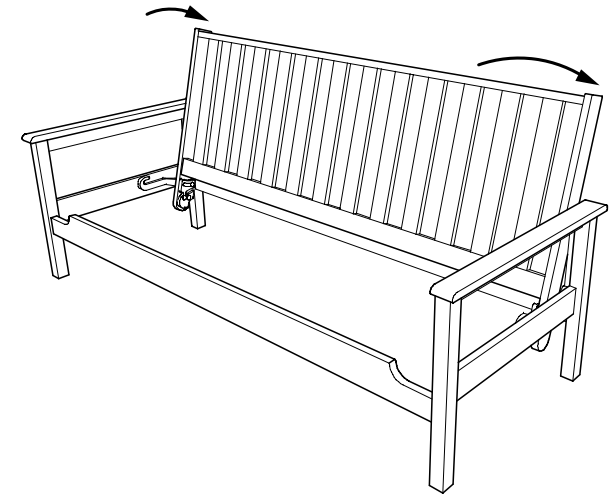

**3C** Gently lift the Back Deck so the Top Roller goes inside the Roller Guide.

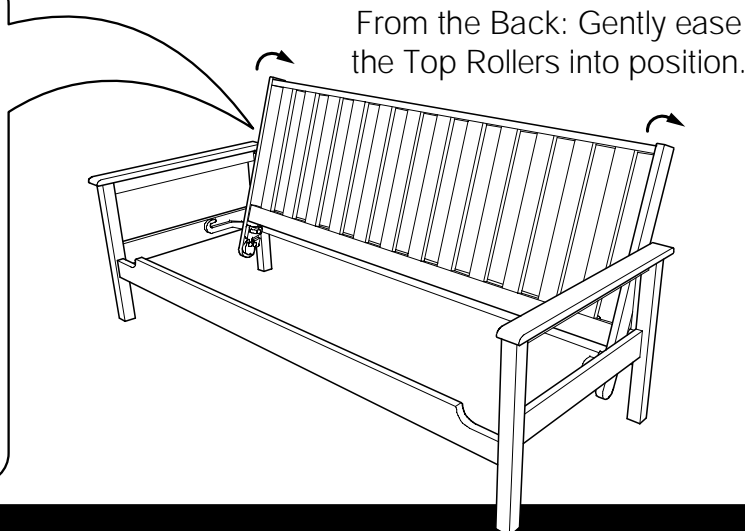
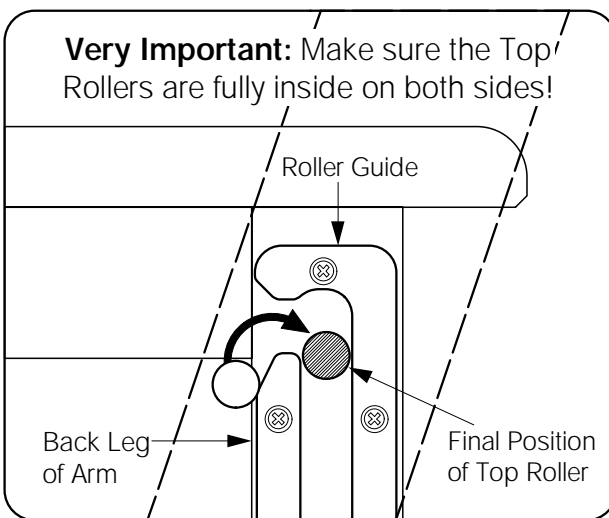

**3D** Gently Lower the Back down until it is lying flat.

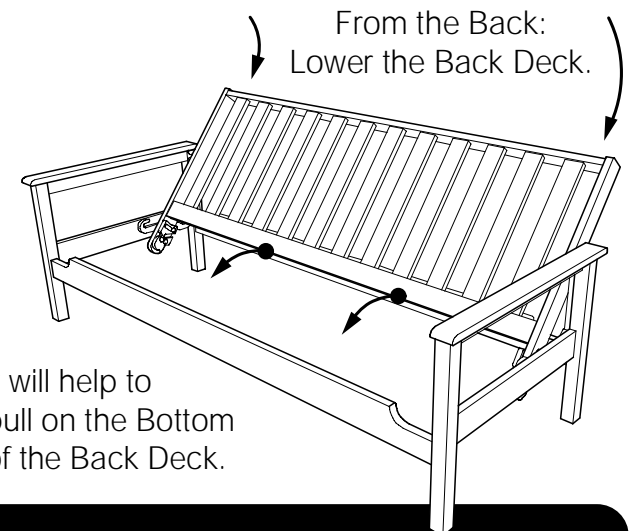

### 4A Hook the Seat Deck onto the Snapper.

Lift the Seat Deck in vertically, so the Pins meet with the Rubber Snapper. The head of the Snapper should fit **between both Pins**.

Just remember: •The Top Pin - fits over the top,  
•The Lower Pin - goes underneath.

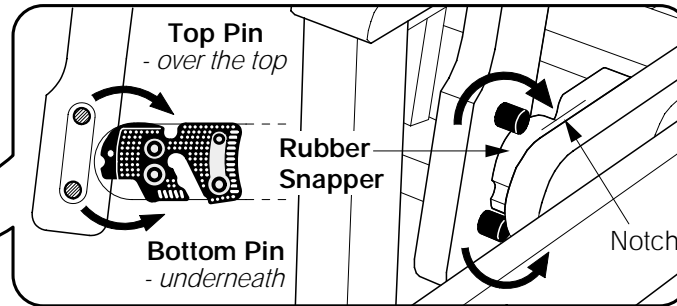
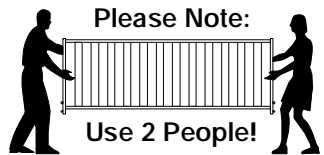
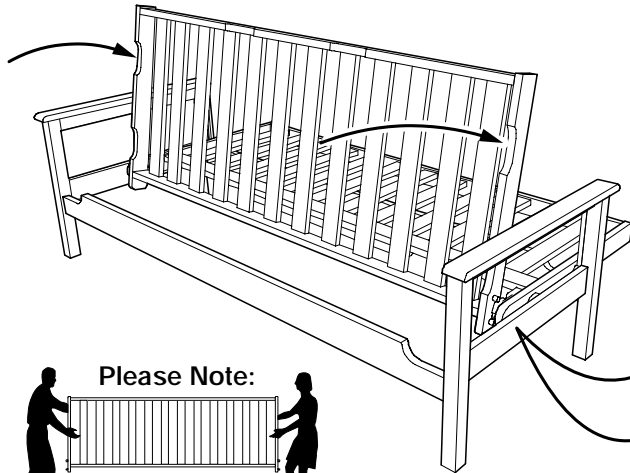

### 4B Pull the Seat over the "Snap Point."

You will need to Pull Hard.



With the Top Pin **inside the notch** on the Rubber Snapper, put your foot on the Back Deck and pull the Seat over the "Snap Point"

### 4C Push down on the Seat, and the Back will Lift.

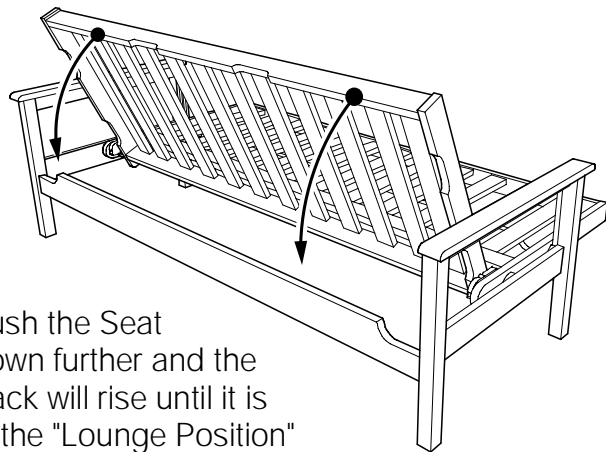

Push the Seat down further and the Back will rise until it is in the "Lounge Position"

### 4D This is the Lounge Position.

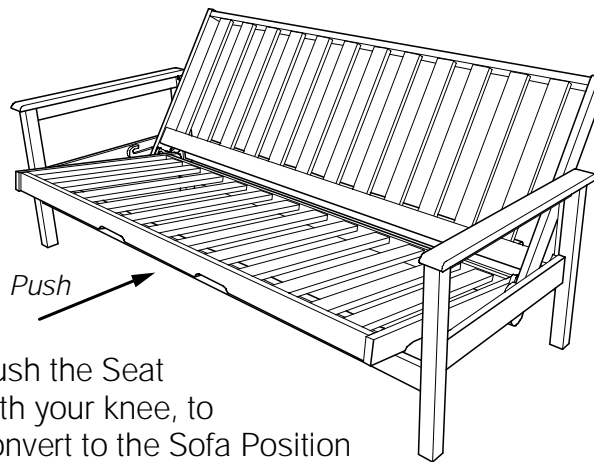

Push the Seat with your knee, to convert to the Sofa Position

### 4E This is the Sofa Position.



Add Mattress and Enjoy! See separate page for Operating Instructions.

**5A** From the Bed position, lift the Seat.

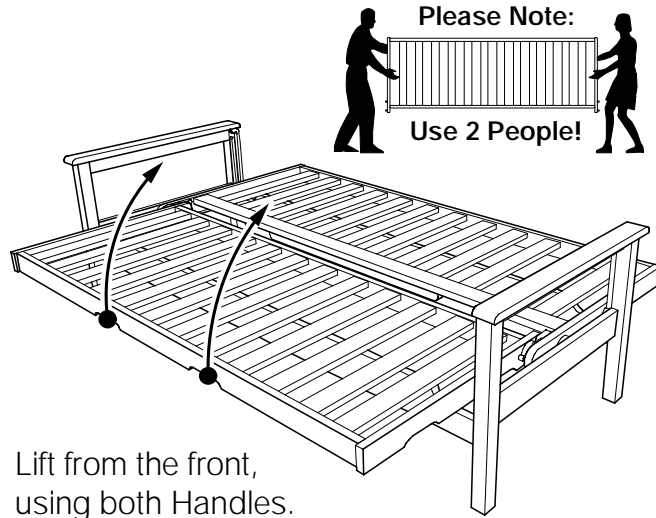

**5B** Lift the Seat all the way.

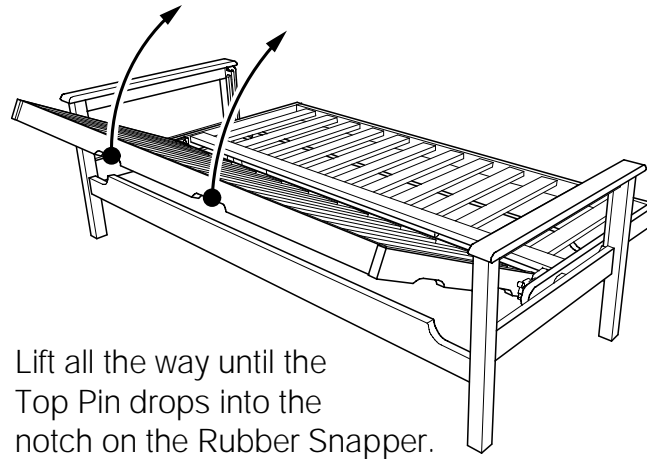

**5C** Push the Seat over the "Snap Point."

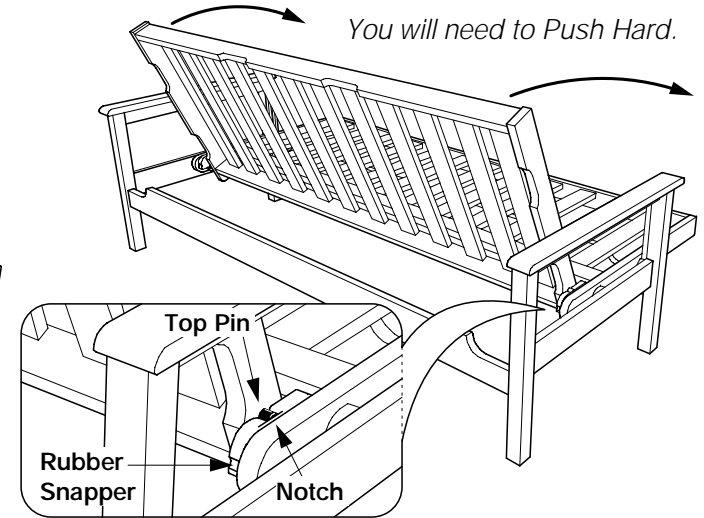

**5D** From the Back, lift out the Top Pin and ease the Seat Deck forward.

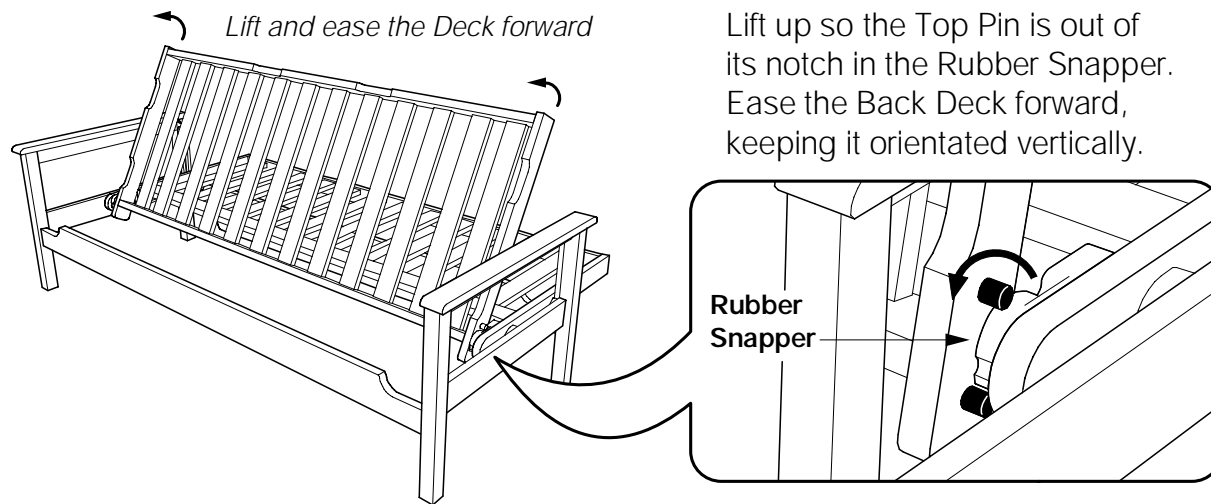

**5E** Lift the Seat clear of the frame.



**6A** Lift the Back Deck up.

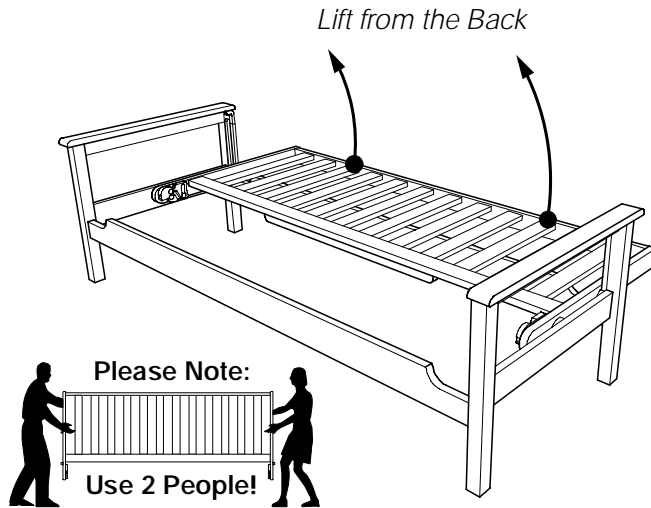

**6B** Lift Back Deck so the Top Roller is clear of the Back Leg.

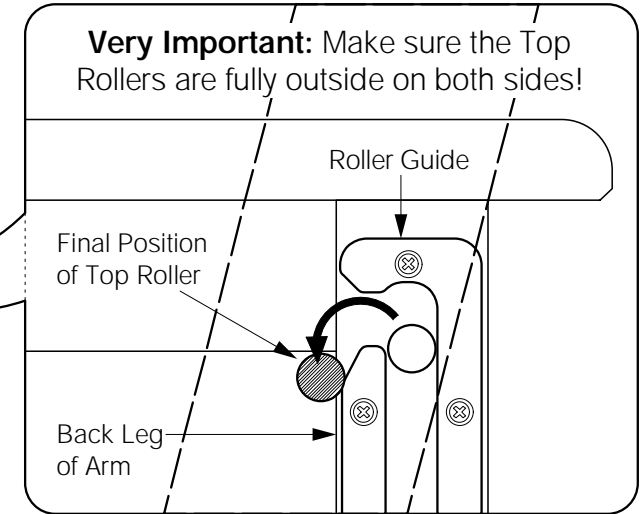
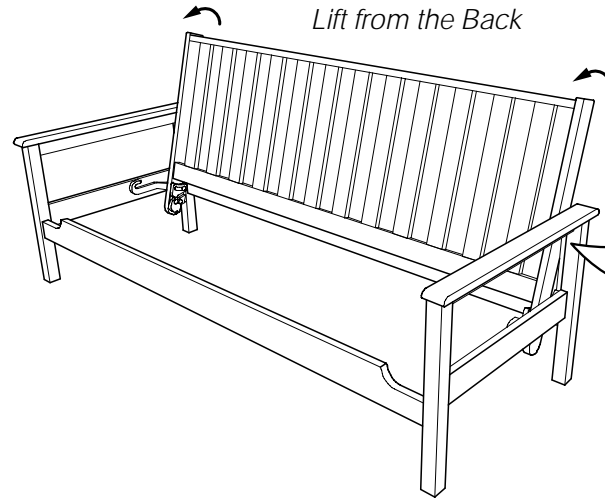

**6C** Push the Deck forward at the top.

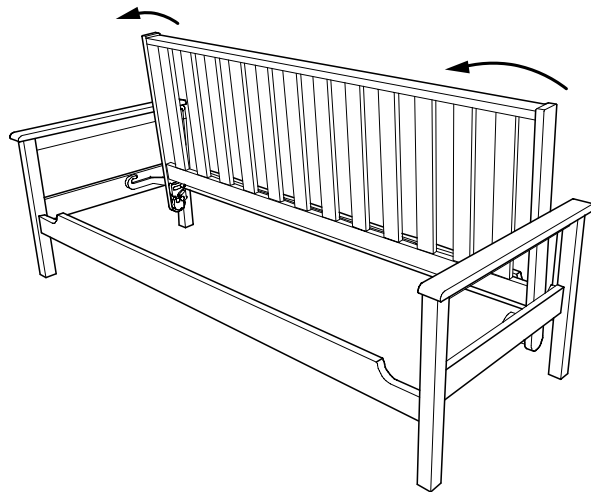

**6D** Lift the Back away from the Arms.

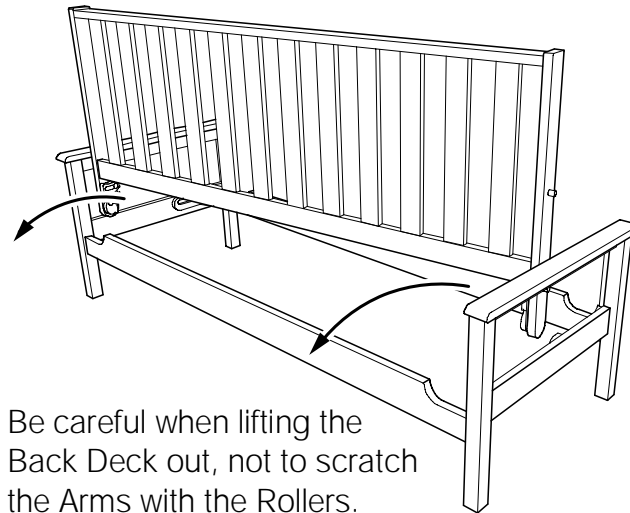

**6E** Undo the Stretcher Bolts.

